

Inline and Shield-Break Joint EHVS for 123 kV up to 170 kV

Application

The joint is a pre-fabricated three-piece design for voltage classes up to 170 kV. Polymeric insulated cables of various designs can be adopted with respect to shielding and metal sheath.

Features

- Pre-fabricated three-piece joint design
- Torque-controlled conductor sleeves
- Integrated moisture barrier using H/S components
- Short cut-back dimensions
- No special tools required to install the joint
- Can adapt shield-break applications
- Cable size transition is possible
- Factory tested Si-rubber parts
- Type tested according to IEC 60840 and IEEE 404 standards



Inline and Shield-Break Joint for 123 kV up to 170 kV

Inline Joint

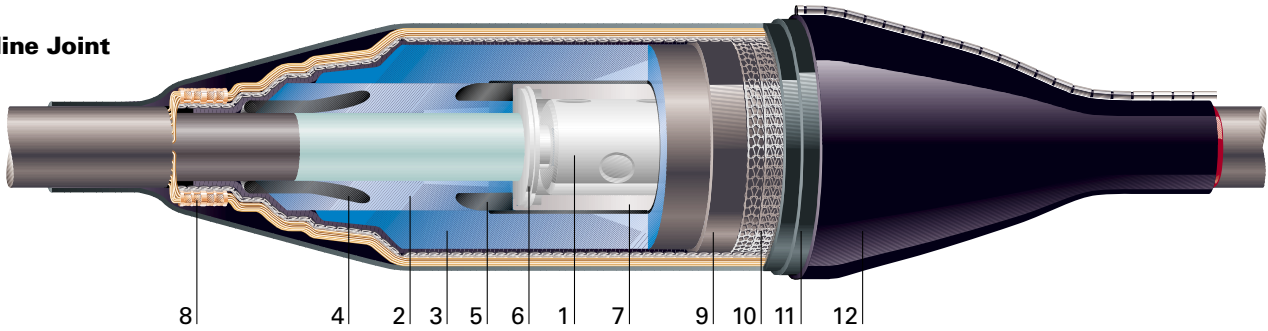

Shield-Break Joint

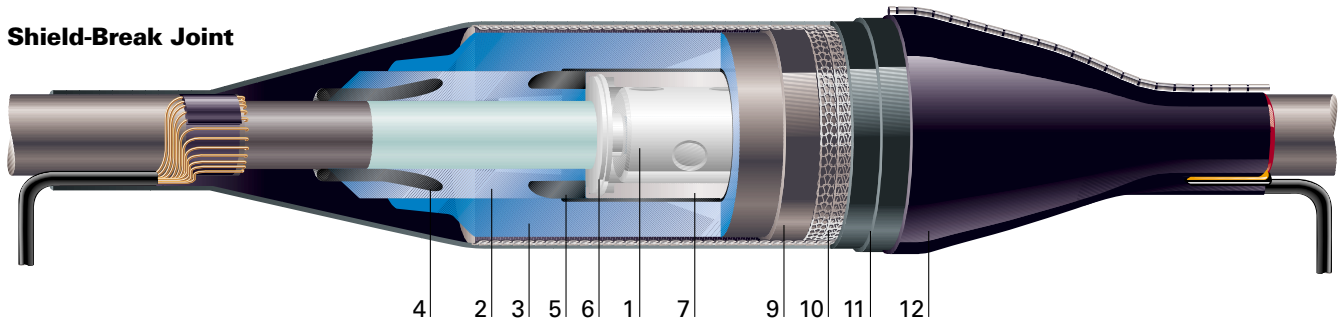

- 1 Mechanical connector
- 2 Adapter
- 3 Main body
- 4 Stress cone
- 5 HV electrode
- 6 Fixing ring
- 7 Metal shielding clamp
- 8 Solderless shield connection
- 9 Conductive tubing
- 10 Copper mesh
- 11 Insulating tubing
- 12 Outer protection with integrated moisture barrier

Major Design Elements

The joint consists of connector (1), cable adapters (2) – including stress cones and main joint body (3) – containing Faraday cage (7) and outer serving by heat-shrink technology (9,12). The conductors of the cable are connected by a mechanical connector sleeve (1) using torque controlled shear-off bolts. The connector sleeve is suitable for stranded aluminium and copper conductors but can be easily modified to accept solid conductors as well. The Si-rubber cable adapters (2), accommodating the various cable insulation diameters, build up the connection area to an almost constant

diameter. This allows to cover different cable cross-sections with just one main insulation joint body (3). Therefore cross-section transitions are possible without any extra components.

No extra tooling is needed to push-on the Si-rubber cable adapters (2) and the Si-rubber joint main body (3) due to its excellent elasticity.

A metal shielding clamp (7) on top of the connector ensures perfect heat transmission and a smooth interface fit. The fixing rings (6) keep the cable adapter and the cable dielectric in position.

During the installation the main body is parked on the over sheath of the cable. This keeps the cut back length and cable preparation time as short as possible. Mechanical solderless connector technologies (8) are used to connect metal shields – copper wires, metal sheath and CAS. Heat-shrink technologies (9,12) replace the cable serving and the moisture barrier. The joint concept is similar for the shield-break joints, despite the shield continuity. Special sealant components make it possible to use double-insulated ground leads, and thereby to utilise the proven heat-shrink technology.

All of the above information, including drawings, illustrations and graphic designs, reflects our present understanding and is to the best of our knowledge and belief correct and reliable. Users, however, should independently evaluate the suitability of each product for the desired application. Under no circumstances does this constitute an assurance of any particular quality or performance. Such an assurance is only provided in the context of our product specifications or explicit contractual arrangements. Our liability for these products is set forth in our standard terms and conditions of sale. ALR, AMP, AXICOM, B&H, BOWTHORPE EMP, CROMPTON INSTRUMENTS, DORMAN SMITH, DULMISON, GURO, HELLSTERN, LA PRAIRIE, MORLYNN, RAYCHEM, and SIMEL are trademarks.



Energy Division – a pioneer in the development of economical solutions for the electrical power industry. Our product range includes: cable accessories, connectors & fittings, electrical equipment, instruments, lighting controls, insulators & insulation enhancement and surge arresters.

For more information and your country contact person, please visit us at: <http://energy.tycoelectronics.com>

Tyco Electronics Raychem GmbH, Energy Division
Finsinger Feld 1, 85521 Ottobrunn/Munich, Germany
Phone: +49-89-6089-0, Fax: +49-89-6096345